

Documentation Vacuum Angle Valve 35" / DN 900

WER Dok.E.02.077.STUS

1.	Introduction / Safety Instructions
2.	Description
3.	Dimensions
4.	Technical Data
5.	Assembly Instructions
6.	Actuator
7.	Maintenance Instructions
8.	Spare Parts
9.	Order Numbers Angle Valves
10.	Warranty conditions



1. Introduction / Safety Instructions

This documentation should be carefully read before installation and operation of this vacuum gate valve, in order to avoid harm to personnel or damage to materials. All statutory rules and regulations must be observed.

2. Description

Angle valves are valves which are often used in vacuum technology systems are used and distinguished openable and close by low vibration. WERNIG-Valves are made to order, thereby versatile options possible.

Standard Features:

- Bypass flange: DN 100 ISO-K, flanged blind
- Drive electro pneumatic (normally closed) with pilot valve 24 V and non-contact limit sensors
- Material quality: Carbon-Steel, Valve plate gasket Viton, all other gaskets NBR.

Options:

- Additional outlet flanges
- Other pilot valve voltages
- Safety position normally open
- Various material combinations possible, for example complete stainless steel
- Exterior paint to customer's specifications

Example of use: Shut-off valve for the suction side of diffusion pumps

3. Dimensions

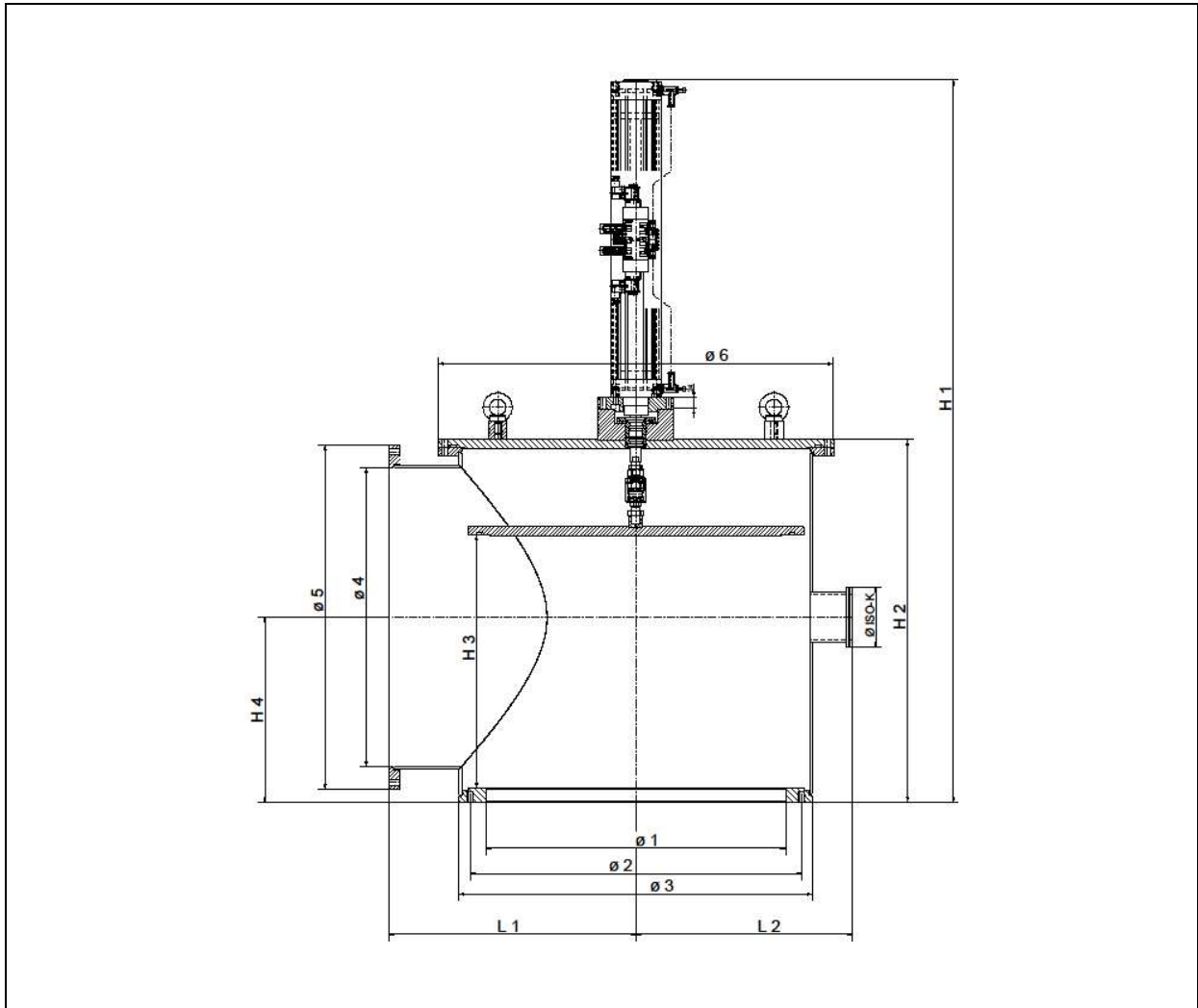

Nominal width DN	mm			35"/DN 900
Bypass flange ø ISO-K	mm			DN 100
Measure H 1	mm			2230
Measure H 2	mm			1162
Measure H 3	mm			734
Measure H 4	mm			600
Measure L 1	mm			645
Measure L2	mm			600
Measure ø 1	mm			889
Measure ø 2	mm			PC 977,9
Measure ø 3	mm			1060
Measure ø 4	mm			889
Measure ø 5	mm			1060
Measure ø 6	mm			1120
Weight	kg			790

4. Technical Data

Angle valve DN			35"/DN 900
Mounting position		vertical, pneumatic cylinder on top	
Conductance	l/s		40000
Actuator		Pneumatic	
Max. pressure difference	mbar	100	
Opening time ¹	Sec.		~ 9
Closing time ¹	Sec.		~ 9
Individual leakage rate	mbar*l/s	< 1 x 10 ⁻⁷	
Pressure range	mbar	1 x 10 ⁻⁶ to atmospheric pressure	
Max. working temperature	°C	60	
Material quality		Carbon-Steel (Standard)	
Material quality		Valve plate gasket VITON (Standard)	
Material quality		All other gaskets NBR (Standard)	
Painting ²		Inside vacuum paint maroon / Outside RAL 7035	
Pilot valve	V / DC	24 (Standard)	

5. Assembly Instructions

The installation position of the valves is normally vertical, pneumatic cylinders above. Installation may only be carried out under clean, standard conditions in vacuum technology. It is particularly important to ensure that the sealing surfaces are not damaged. In case of faulty, messy installation and improper operation of any warranty claim expires.

Additional forces from attachments etc. are to be avoided. Decouplings for example bellow units are preferable.

Compressed air

Only clean, dry and lightly oiled compressed air must be used !

Pressure range: 5 – 7 bar_g / 72 – 101 psig

¹ ΔP = 0 bar, compressed air 6 bar_a

² Standard, customer requirements possible !



Compressed air do not connect when the valve is installed in the vacuum system, and when the valve disc or other moving parts can not be touched.

6. Actuator

Maintenance-free, double-acting pneumatic standard cylinder.

Angle valve DN			35"/DN 900	
Standard cylinder			WER 02077.07	
Flexo-coupling			WER 02077.08	
Pilot valve			WER 02077.09	
Solenoid			WER 02077.10	
Silencer			WER 02077.15	
Proximity switch			WER 02077.12	
Throttle check valve			WER 02077.14	

7. Maintenance Instructions

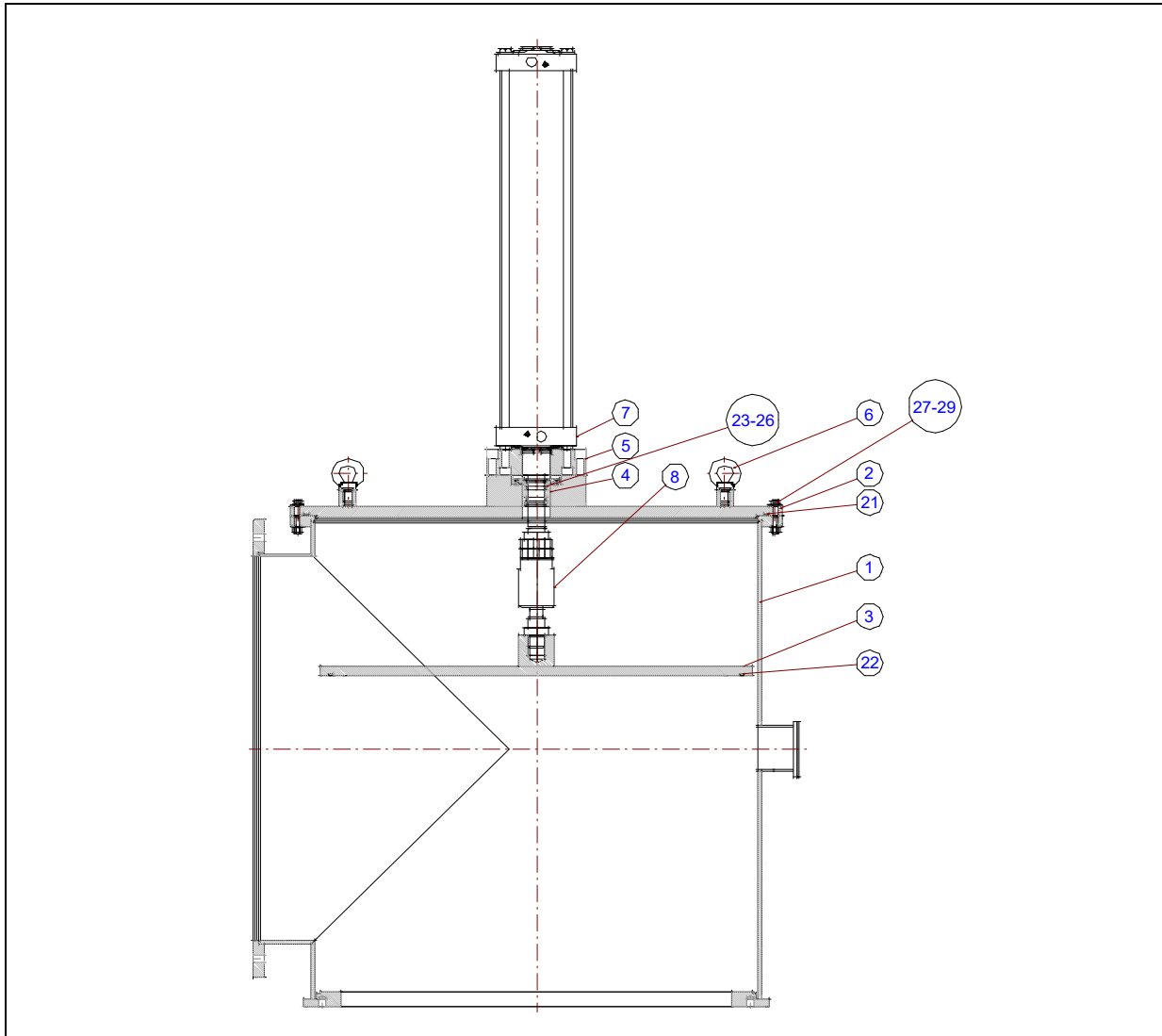

Change the valve plate gasket, Item 22

- Disassembly of the valve bonnet item 2 by loosening item 27, 28, 29
- Complete lifting of the valve bonnet with a lifting tool (crane), eyebolts are present on the lid.
- Replacement of the seals that are included in gasket kit (item 21, 22 + 23-26) and cleaning the valve inside
- Mounting of upper and lower part

All maintenance can be taken over by WERNIG Maschinen- und Apparatebau GmbH & Co. KG. For this purpose, please contact us.

8. Spare Parts

Nominal width	35"/DN 900	
Gasket kit (Item 21 und 22)	WER DS01.02077	
Gasket kit pressure stage casing (Item 23 bis 26)	WER DS02.02056	

Further spare parts on request.

9. Order Numbers

Nominal width	Material quality	Switching cycles	Order numbers
35"/DN 900	Carbon steel		WER 02077.STUS

Further options on request.

10. Warranty conditions

1. The manufacturer assumes the guarantee for all manufacturing or assembly defects on the product for a period of 12 months after commissioning, maximum 15 months after delivery (delivery date is decisive).
2. Parts and assemblies that are not from the supplier are subject to the supplier's warranty
3. The warranty covers only defective parts. All other costs (travel, labor costs, transportation, loading and unloading, penalties, etc ...) shall be borne by the operator.
4. If the manufacturer considers this to be appropriate, the product must be transported to the company for the purpose of diagnosis and repair with the appropriate means
5. The manufacturer rejects any legal liability for damages or accidents that are directly or indirectly attributable to our materials, regardless of the guarantee period.
6. The warranty expires if:
 - The product is rebuilt in a manner not approved by the manufacturer, replacement parts not supplied by the manufacturer, or an unauthorized workshop on the product.
 - The product is used without having previously read the documentation
 - The product is operated outside the limits of use (temperature / pressure, etc.)
 - The product is damaged by excessive use.
 - The product is negatively affected by contamination
 - The copy of this warranty has not been duly completed and sent to WERNIG Maschinen- und Apparatebau GmbH & Co. KG
7. The operator declares that the documentation has been read and understood before commissioning.
8. Defective parts or spare parts covered by the warranty are made available to the customer. Free of charge will only take place if the faulty parts or spare parts have been received by the manufacturer for inspection.
9. Transport: Complaints of damages during transport are not accepted, these are to be addressed to the transport company.

ATTENTION. THIS WARRANTY APPLIES ONLY IF A COPY OF THIS DOCUMENT IS SIGNED TO THE MANUFACTURER.

Product: _____

Part number: _____

Serial number: _____

Operator: _____

Date: _____

Printed Name: _____

Signature: _____